

Schröder

Axia 3

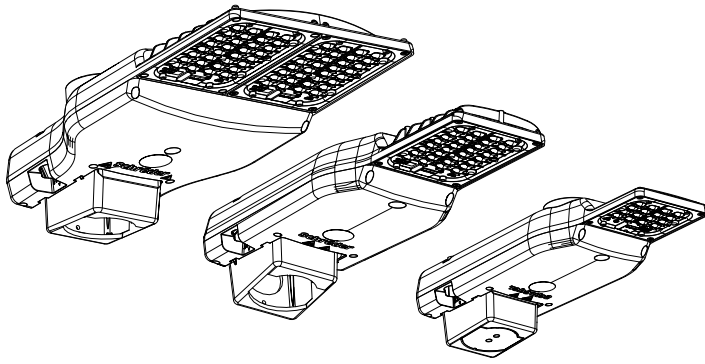

ENG	INSTALLATION INSTRUCTIONS	ITA	ISTRUZIONI DI INSTALLAZIONE	NLD	INSTALLATIE INSTRUCTIES	DAN	INSTALLATIONSVEJLEDNING	HUN	TELEPÍTÉSI ÚTMUTATÓ
DEU	INSTALLATIONSANLEITUNG	POL	INSTRUKCJE MONTAŻU	RUS	Инструкции по установке	RON	INSTRUCȚIUNI DE INSTALARE	CHI	安装说明
FRA	INSTRUCTIONS DE MONTAGE	SPA	INSTRUCCIONES DE INSTALACIÓN	POR	INSTRUÇÕES DE INSTALAÇÃO	SWE	INSTALLATIONSANVISNING	UKR	Інструкції з монтажу
SRP	UPUTSTVA ZA INSTALACIJU	AR	تعليمات التركيب						

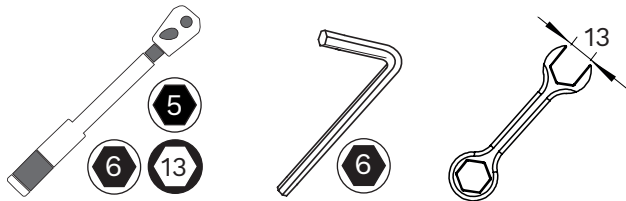

	Axia 3.1	Axia 3.2	Axia 3.3
A	513 mm	585 mm	550 mm
B	191 mm	191 mm	277 mm
C	130 mm	130 mm	130 mm
C _x	0,032m ²	0,030m ²	0,042m ²
kg	3,6 kg	4,8 kg	6 kg

Axia 3.1

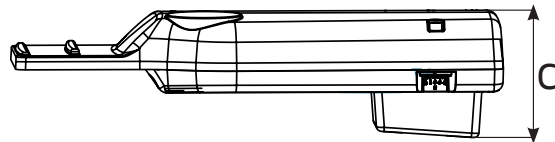
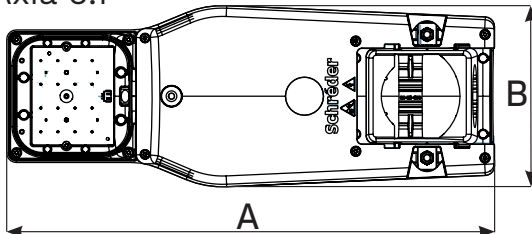

Axia 3.2

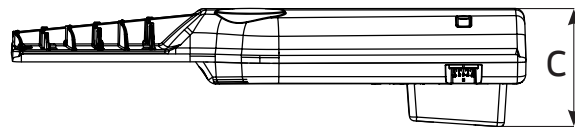
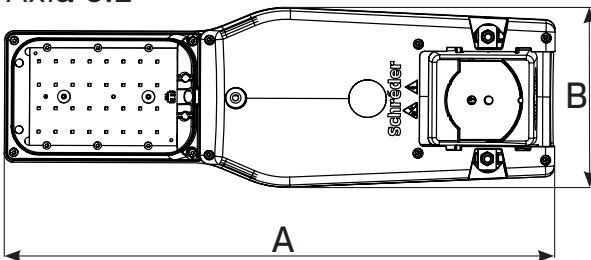

Axia 3.3

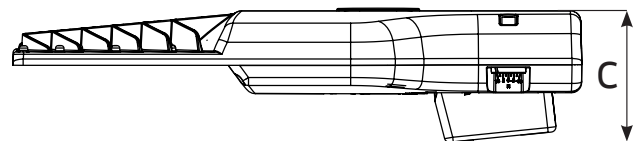
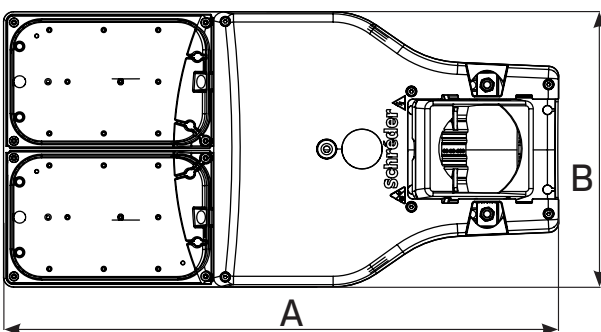

A 1 Release

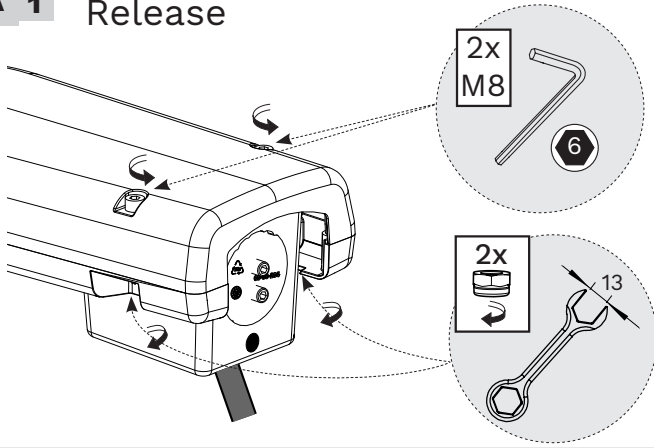

2

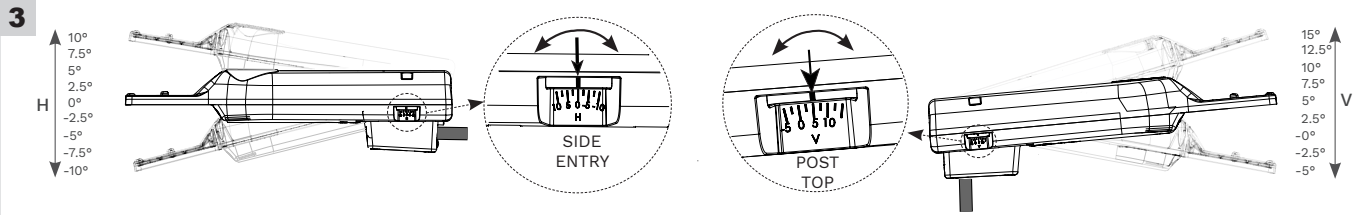
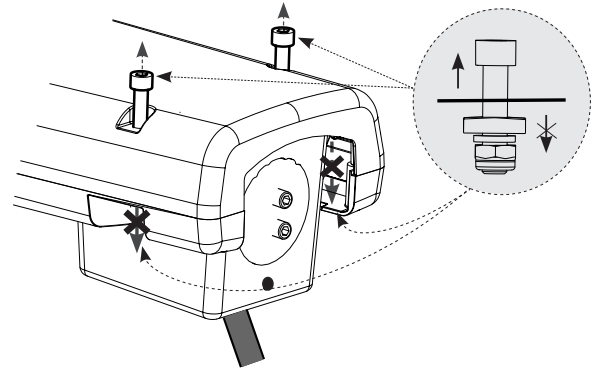

4 Tighten

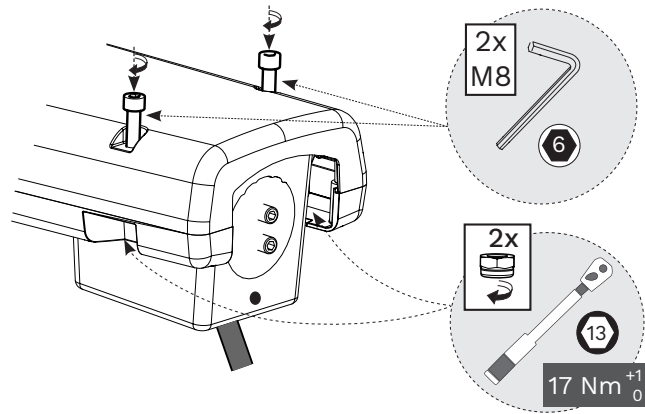

B 1 2

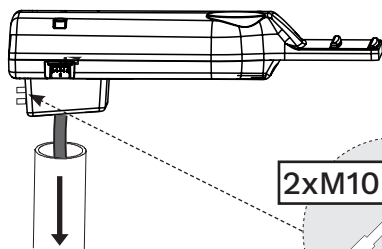

POST TOP = V

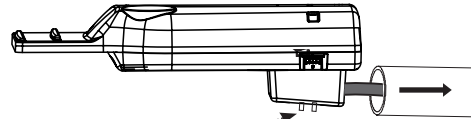

SIDE ENTRY = H

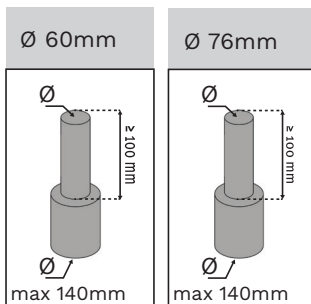
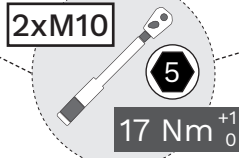

**No lubricant!
Use only TIKAL Tef-Gel.**

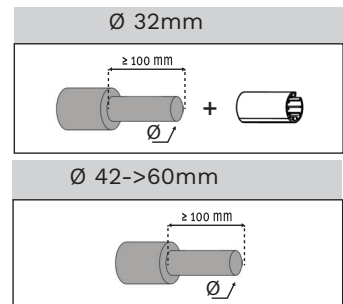

C

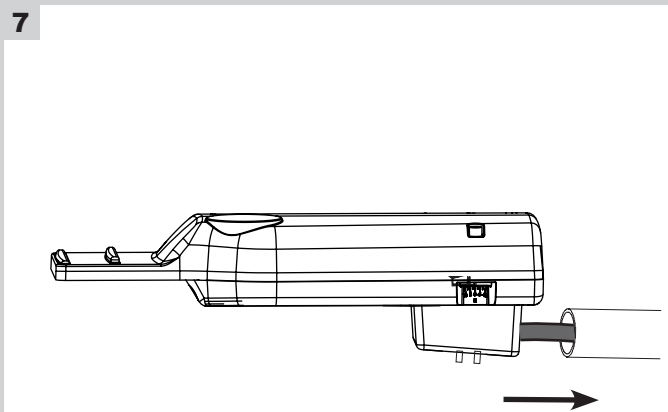
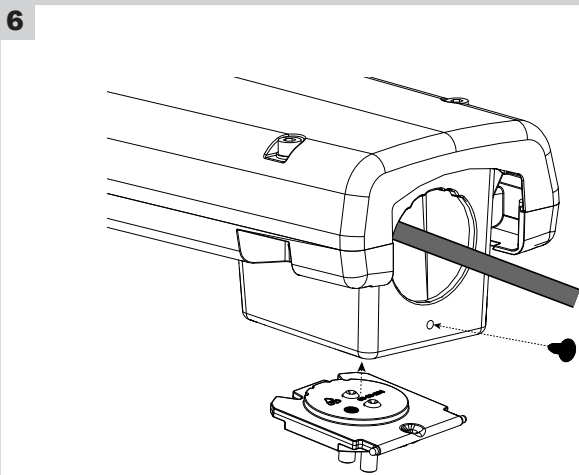
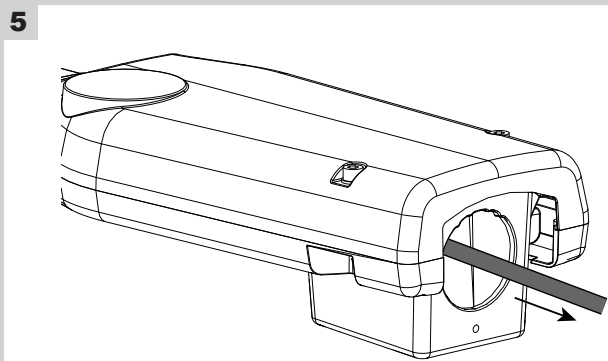
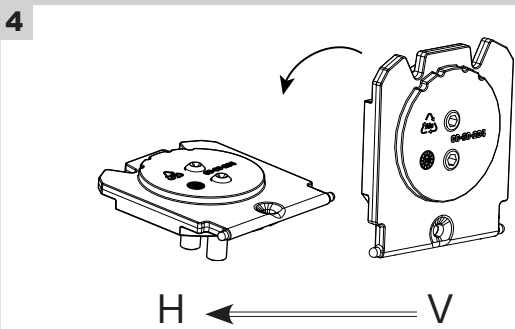
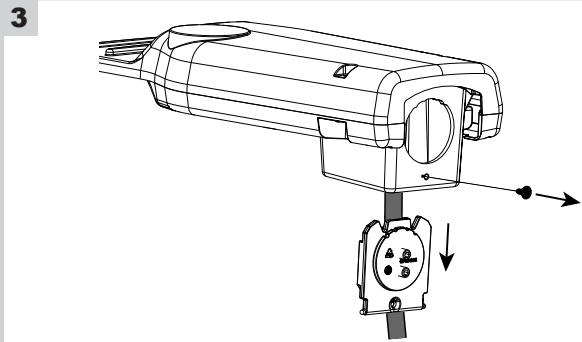
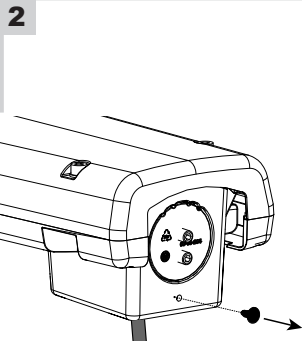
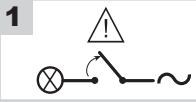
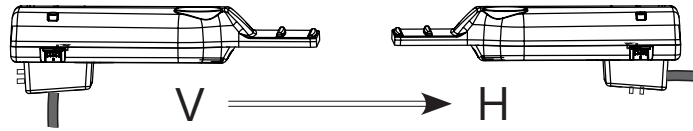

8

	 Dim	Bi-Power Switching line	 No Dim
	 5 G 1.5mm ² D-,D+,PE,N,L	 4 G 2.5mm ² 4 G 1.5mm ² L,Lp,PE,N,	 3 G 2.5mm ² 3 G 1.5mm ² L,PE,N,
	 4 x 2.5mm ² 4 x 1.5mm ² D-,D+,N,L	 3 x 2.5mm ² 3 x 1.5mm ² L,Lp,N,	 2 x 2.5mm ² 2 x 1.5mm ² L,N

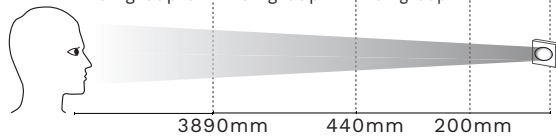

Table with 5 columns: Language (ENG, ITA, NLD, DAN, DEU, POL, RUS, RON, FRA, SPA, POR, SWE, HUN, CHI, UKR, SRP, AR), Risk Group (0, 1, 2), and Safety Instructions. Each cell contains safety text in the respective language.

Copyright © Schreder S.A. 2021 - Executive Publisher: Stéphane Halleux - B-4000 Liège, Rue de Mons 3 (Belgium) - The information, descriptions and illustrations herein are only of an indicative nature and subject to changes without notice.